



**MIDDLE PAXTON
TOWNSHIP
CODE SERVICES**

**** OFFICE USE ONLY ****

Date Received: _____
 Zoning District: _____
 Tax Parcel No.: _____
 Zoning Permit No.: _____

APPLICATION FOR ZONING PERMIT

Application is hereby made for a permit in conformity with requirements of the Pennsylvania Municipalities Planning Code, Current Local Zoning Ordinance and any amendments thereto for the following described work:

I. PROPERTY INFORMATION

Residential Non-Residential

Municipality: _____ Development: _____ Lot: _____ Section: _____

Proposed Work Site Address: _____ Tax Parcel ID: _____

Lot Width: _____ Lot Depth: _____ Lot Size: _____
(Acres or Sq.ft.)

Property within Floodplain Yes No If Yes, Market Value of Property: _____

Do you have an elevation certificate Yes No If Yes, please attach a copy with submission

Property located in Historic District Yes No If Yes, also complete the Application for COA

II. CONTACT INFORMATION

Applicant: _____ email: _____

Mailing Address: _____ City: _____ State: _____ Zip: _____

Phone: _____ Phone: _____ Fax: _____

(If different than Applicant)

Property Owner: _____ email: _____

Mailing Address: _____ City: _____ State: _____ Zip: _____

Phone: _____ Phone: _____ Fax: _____

Contractor: _____ email: _____

Mailing Address: _____ City: _____ State: _____ Zip: _____

Phone: _____ Phone: _____ Fax: _____

III. CONSTRUCTION

Erect a Structure Principal Accessory **Size** (length, width and height) i.e., 20' L, 15' W, 12' H: _____

Add to a Structure Principal Accessory **Size** (length, width and height) i.e., 20' L, 15' W, 12' H: _____

Change of Use Existing use: _____ Proposed use: _____

Erect a Fence Height: _____ (feet) **Install a Swimming Pool** In-ground Above-ground

Erect a Sign (Provide sign proof along with plot plan) **Sign Copy Change** (Provide sign proof)

Type: Wall Mounted Ground Roof Other (Please Specify): _____

Height (distance from top of sign to ground): _____ (feet) **Size** (length and height of sign face) i.e. 6' L x 18" H: _____

Off-street Parking Area or Parking Lot **Establish a Home Occupation**

Other (Please Specify): _____

IV. PROJECT DESCRIPTION Provide a narrative which explains the proposed project based upon the items checked in the previous section (III)

Cost of Construction: _____ **Street Access:** Municipal State Other

Sewage Disposal: Public Sewer On-Lot **Water Supply:** Public Sewer On-Lot

V. PLOT PLAN * Four (4) Sets of all associated drawings ARE REQUIRED WITH EVERY ZONING PERMIT.**

ON THE FOLLOWING PAGE, PLEASE INCLUDE ALL THE FOLLOWING:

1. Indicate the length of all property lines
2. Show all existing and proposed structures on property and the distance from the structure to the property lines
3. Indicate name of streets abutting property
4. Identify all bodies of water and show distance to proposed structure(s)
5. Show septic, well, driveway locations and distance from new structure to septic
6. Label distances from principal structure to proposed accessory structure(s)
7. Physically mark property lines & proposed location of structure onsite prior to submitting zoning application

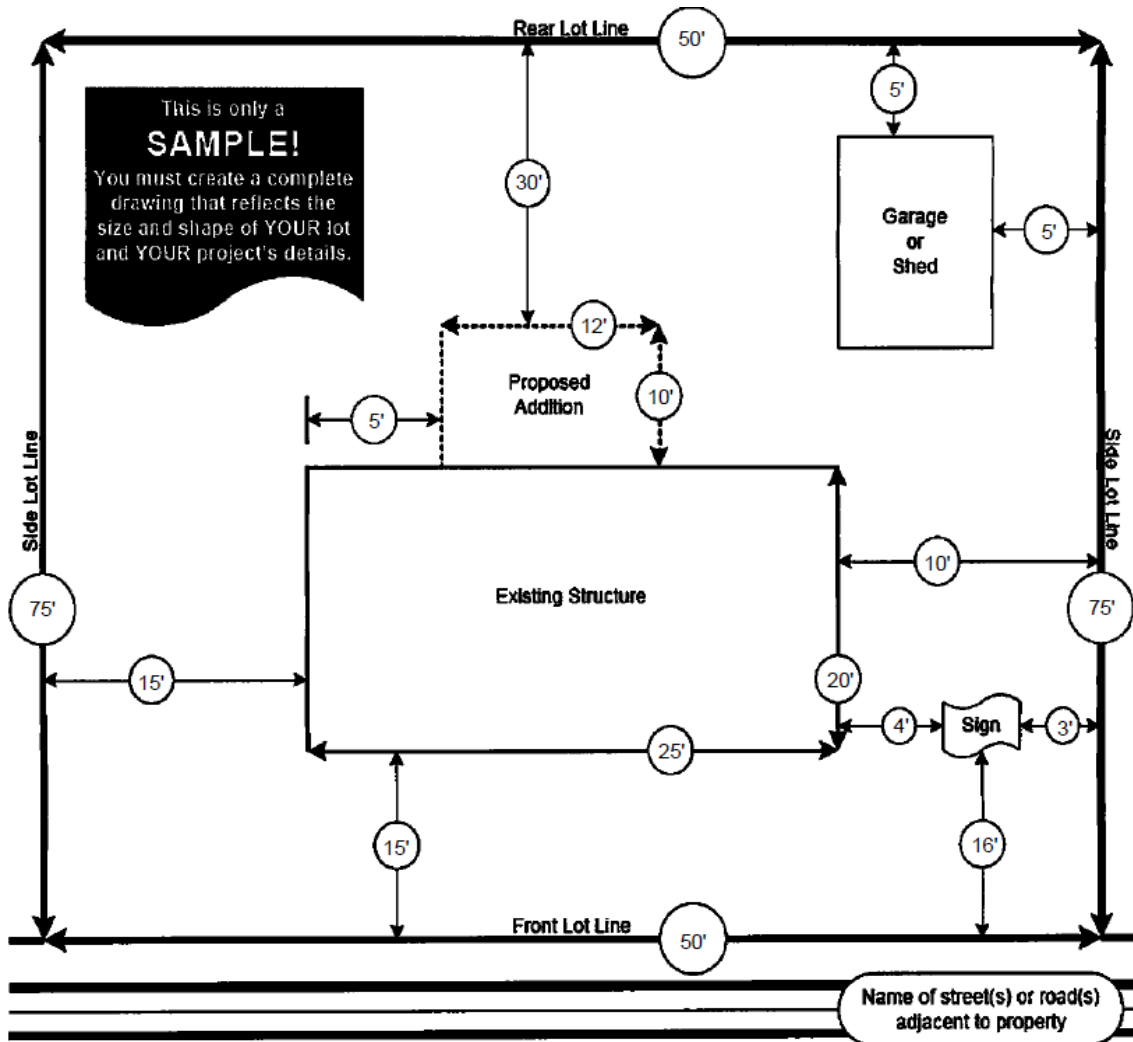

EXISTING & PROPOSED PLOT PLAN & IMPERVIOUS COVERAGES

Impervious Coverage: *A surface that does not absorb rain, including all buildings and other structures, parking areas, driveways, roads, sidewalks, storage areas and areas of concrete and nonporous asphalt and other such areas as shall be determined to be nonporous by the Board of Supervisors and/or Township Engineer.*

EXISTING: Buildings: _____ / Other: _____ (Sq Ft) **PROPOSED** _____ (Sq Ft) = **TOTAL IMP CVG** _____ Sq Ft

Official only: Max. Allowed Impervious (sf) Buildings _____% Other _____% Total _____%

PLOT PLAN

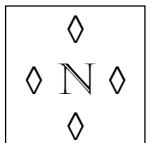

Approved by: _____ Date: _____ Permit No.: _____

I hereby authorize the Municipality Staff to perform inspections related to this application as may be required between the hours of 8 AM and 8 PM. The applicant understands and agrees to comply with the Pennsylvania Municipal Planning Code and Zoning Ordinance, as amended. All information supporting this application shall become part of the records of the Municipality, cannot be returned and may be examined by the public at any time during the normal working hours of the Municipal Office.

Application is hereby made for a permit to erect or alter a structure which shall be located as shown on the attached diagram/plot plan and/or to use the premises for the purposes herewith. The information which precedes, together with the plot plan/diagram, is made part of this application by the undersigned. It is understood and agreed by the applicant that any error, misstatement or misrepresentation of material, fact, either with or without intention on the part of this applicant, such as might or would operate to cause a refusal of this application or any change in the location, size or use of structure or land made subsequent to the issuance of this permit without approval of the Zoning Officer, shall constitute sufficient ground for the revocation of this permit.

Applicant Signature: _____	Date: _____
Owner Signature: _____	Date: _____
BOTH SIGNATURES ARE REQUIRED IF APPLICANT IS DIFFERENT THAN OWNER	

** OFFICE USE ONLY **

Meeting Dates (if applicable)

Historic: _____ Approved: Yes No ZHB:

_____ Approved: Yes No

Planning: _____ Approved: Yes No Other:

_____ Approved: Yes No

PA UCC Construction Permit Required: Yes No

Action Taken: Approved Denied

Zoning Fee: _____

Application Fee Paid: _____

Balance Due: _____

Date Paid: _____

Zoning Officer Signature: _____

Date: _____

If the permit is denied, the zoning officer shall note the applicable sections/basis of denial below:

A copy of the zoning officer's official letter of denial shall be attached to this application.